

HORIZONTAL DRUM ROLLER - DRM-H-3055

APPROX WEIGHT: 344 lbs.
DOES NOT INCLUDE WEIGHT OF POWER OR PACKAGING!!!

*** ANY ADDITIONS, DELETIONS, OR OMISSIONS MUST BE CORRECTED ON THIS DRAWING AS THIS DRAWING WILL BE CONSIDERED ALL INCLUSIVE ***

ALL GRAPHICS PROVIDED ARE FOR REFERENCE ONLY. IF CERTAIN DIMENSIONS ARE CRITICAL PLEASE VERIFY THOSE DIMENSIONS WITH YOUR SALESPERSON

OSHA subpart O.1910.212(a)(4) "Barrels, containers, and drums. Revolving drums, barrels, and containers shall be guarded by an enclosure which is interlocked with the drive mechanism, so that the barrel, drum, or container cannot revolve unless the guard enclosure is in place."

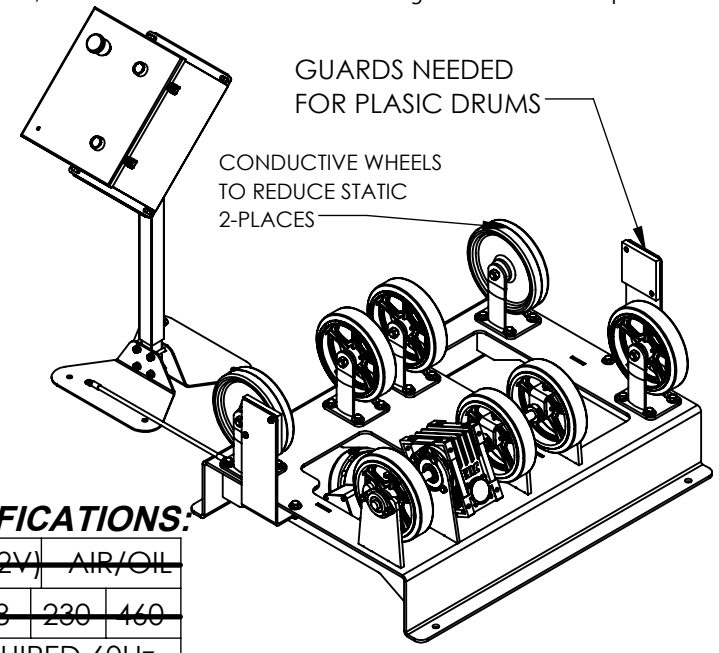
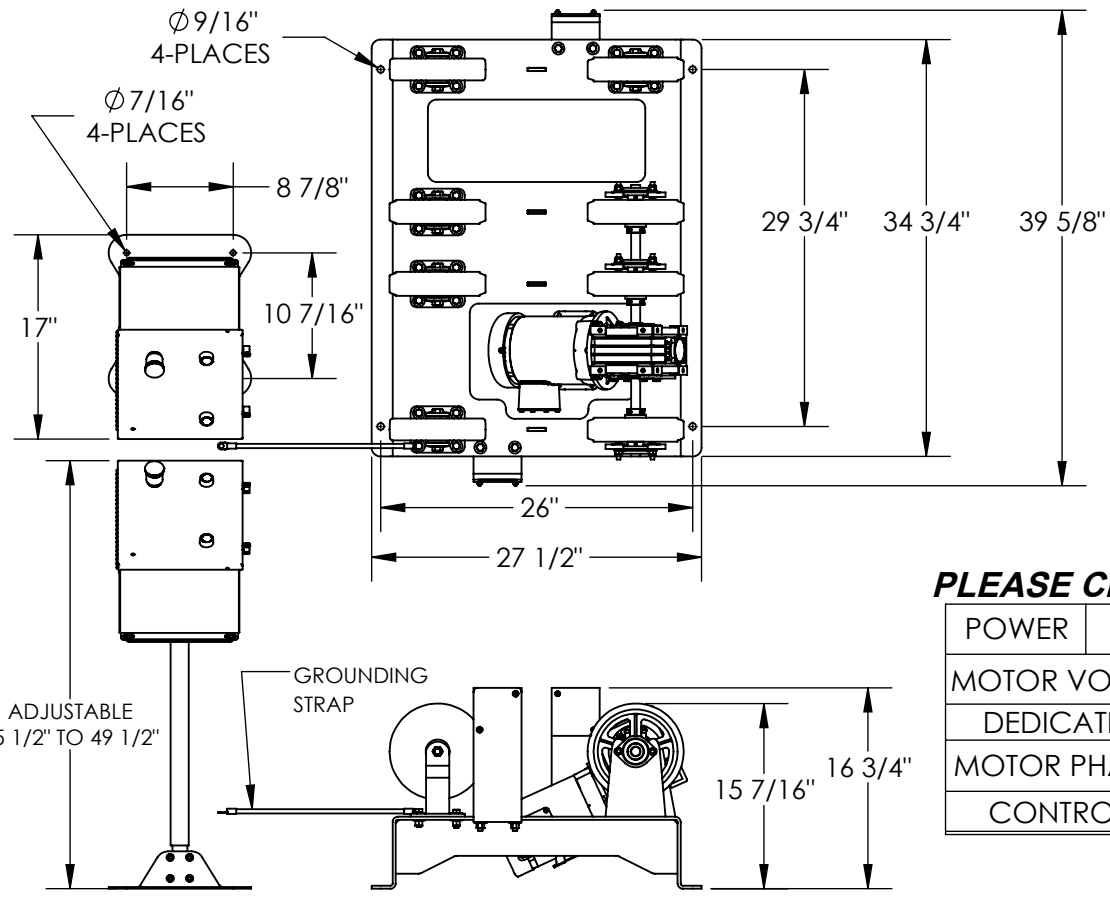

PLEASE CIRCLE SPECIFICATIONS:

POWER	AC	DC (12V)	AIR/OIL
MOTOR VOLTAGE	115	208	230 460
DEDICATED CIRCUIT REQUIRED 60Hz			
MOTOR PHASE	SINGLE	THREE	
CONTROL	HAND	FOOT	

DIMENSION TOLERANCE $\pm 1/4"$

STANDARD FEATURES

- MODEL NUMBER IS DRM-H-3055
- OVERALL WIDTH IS 27 1/2"
- OVERALL LENGTH IS 39 5/8"
- OVERALL HEIGHT IS 16 3/4"
- FOR USE WITH 55 AND 30 GAL. DRUMS
- ADJUSTABLE DRUM ROTATIONAL SPEED
 - 55 GAL. DRUM SPEED IS 7 TO 20 RPM
 - 30 GAL. DRUM SPEED IS 8 TO 25 RPM
- PEDESTAL STAND ADJUSTABLE FROM 35 1/2" TO 49 1/2"
- CONTROLS ON PEDESTAL
- $\phi 7/16"$ PEDESTAL MOUNTING HOLES 4-PLACES
- $\phi 9/16"$ UNIT MOUNTING HOLES 4-PLACES
- MAX CAPACITY IS 1,000 LBS. FOR LIQUIDS AND 300 LBS. FOR DRY PRODUCTS
- TOUGH BAKED IN POWDER COATED BLUE FINISH

SPECIAL FEATURES

NONE

APPROVAL

I, THE UNDERSIGNED, AGREE THAT THE PRODUCT AS REPRESENTED SATISFIES DESIGN AND DIMENSION REQUIREMENTS. I ALSO ACKNOWLEDGE MY DUTY TO CONFIRM PRODUCT AND INSTALLATION COMPLIANCE WITH ALL APPLICABLE FEDERAL, STATE AND LOCAL REGULATIONS AND STANDARDS.

UNITS REQUIRING APPROVAL DRAWINGS OR MODIFIED ARE NON-RETURNABLE

[] As drawn [] As marked

Signed: _____ Date: _____

Printed Name: _____

LEAD TIME WILL START UPON RECEIPT OF SIGNED APPROVAL DRAWING

DISTRIBUTOR'S NAME:		P.O.#
VESTIL MANUFACTURING		X
DRAWN BY: JWW	DATE: 2/8/2021	W.O.#
REFERENCE: X	SCALE: 1:16	X
QUOTED LEAD TIME: X	QUOTE #	FILE NAME:
	X	09-007-225